

Electrification

A revolution for the aviation industry

22 March 2018

Oslo, Norway

AIRBUS

Why electric aircraft?



Less or Zero Emissions

Part of aviation's sustainability plan | Operation close to communities



Reduced Direct Operating Cost

Less parts | higher reliability | lower maintenance cost | lower energy cost



Lower noise

24/7 operations | new landing locations



New functions

Long-range VTOL | Short take-off and landing fixed wing | Improved aero performance

Electric flight: E-Fan 1.0

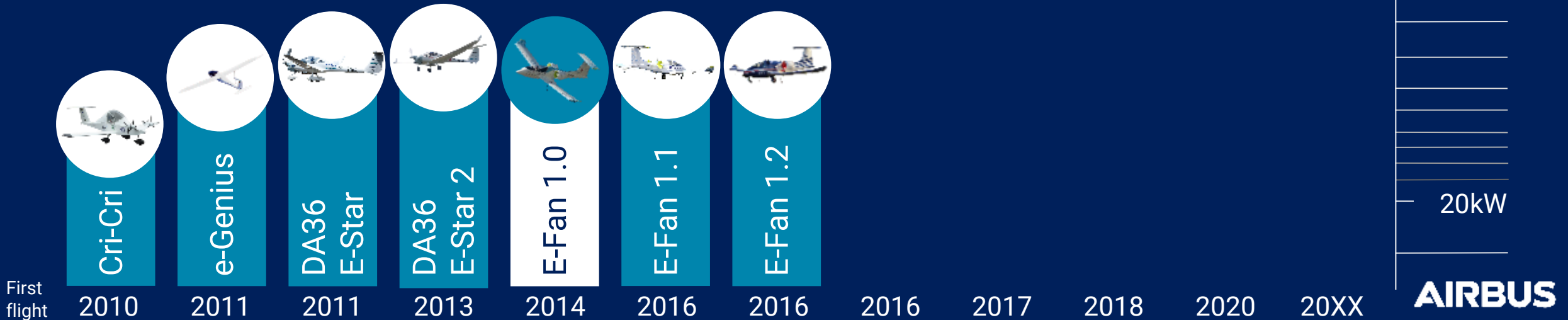

Electric flight: Vahana & CityAirbus

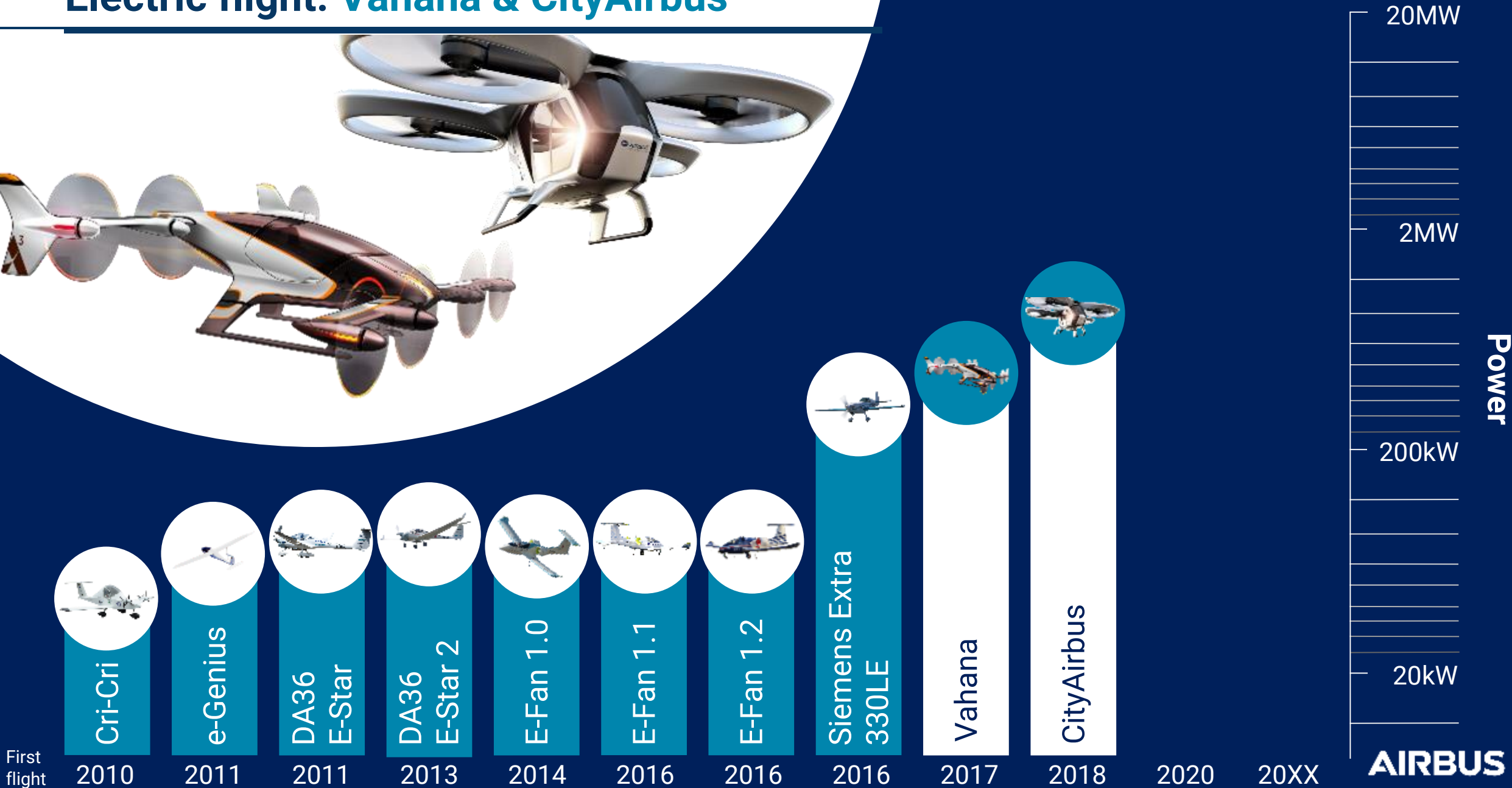

First flight





CityAirbus



Hybrid / Electric flight: E-Fan X

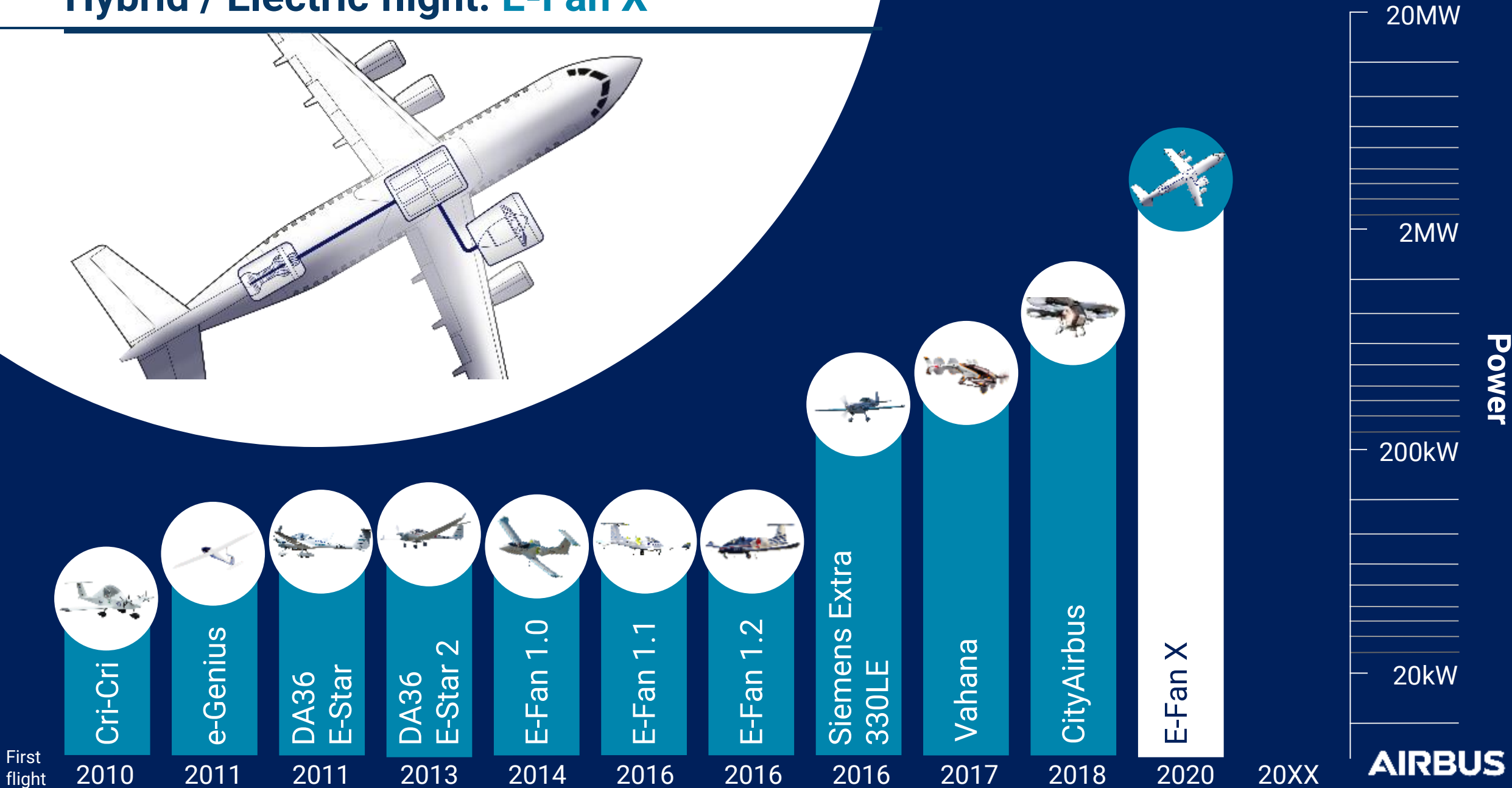
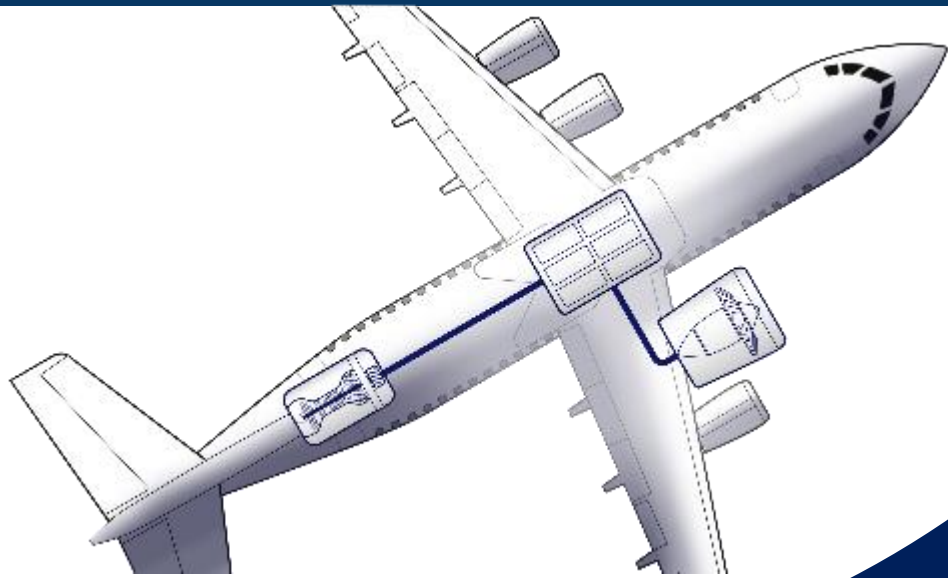

First flight

2010 2011 2011 2013 2014 2016 2016 2016 2017 2018 2020 20XX

AIRBUS



Hybrid / Electric flight: New Single Aisle

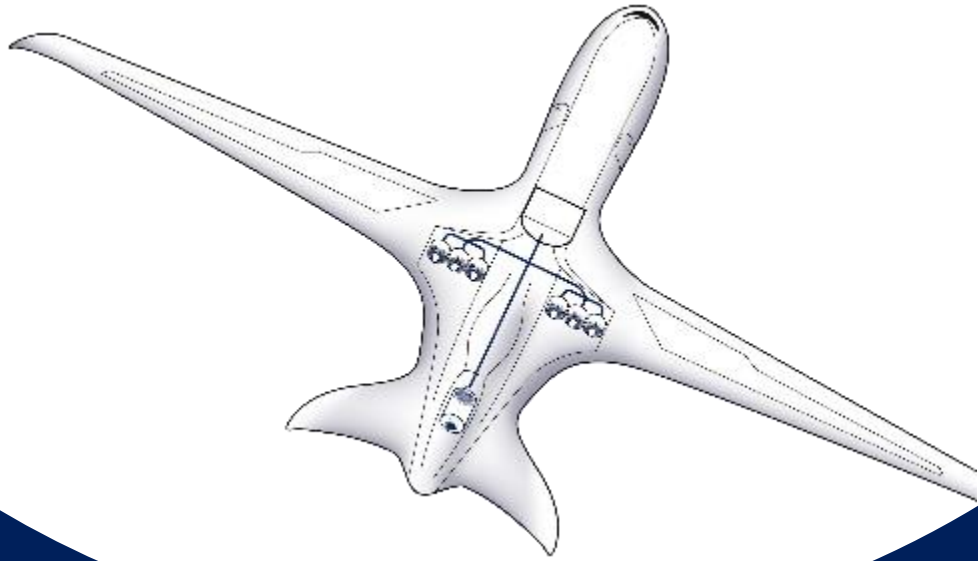

First flight

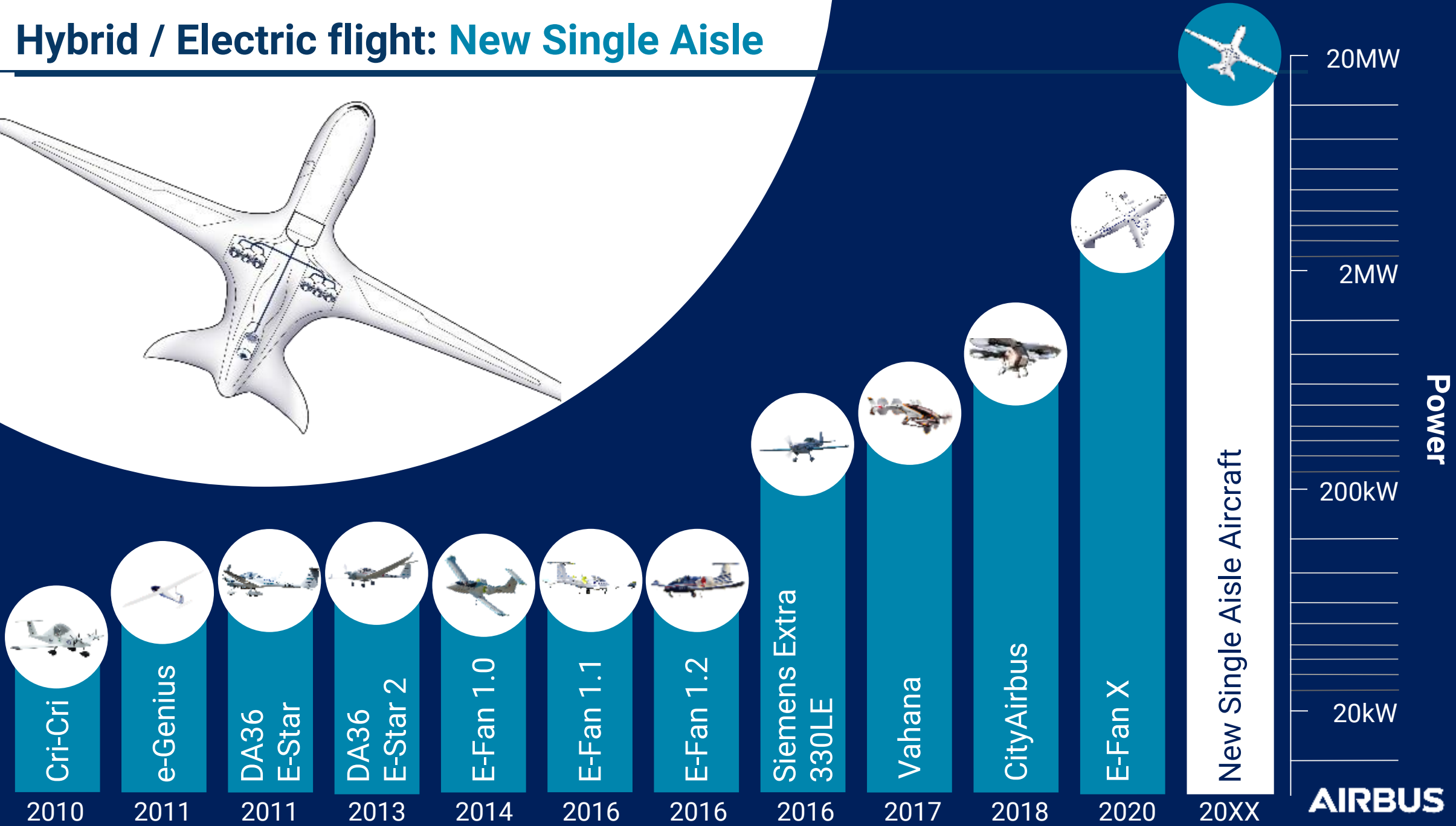

AIRBUS

The transition will require strong teaming

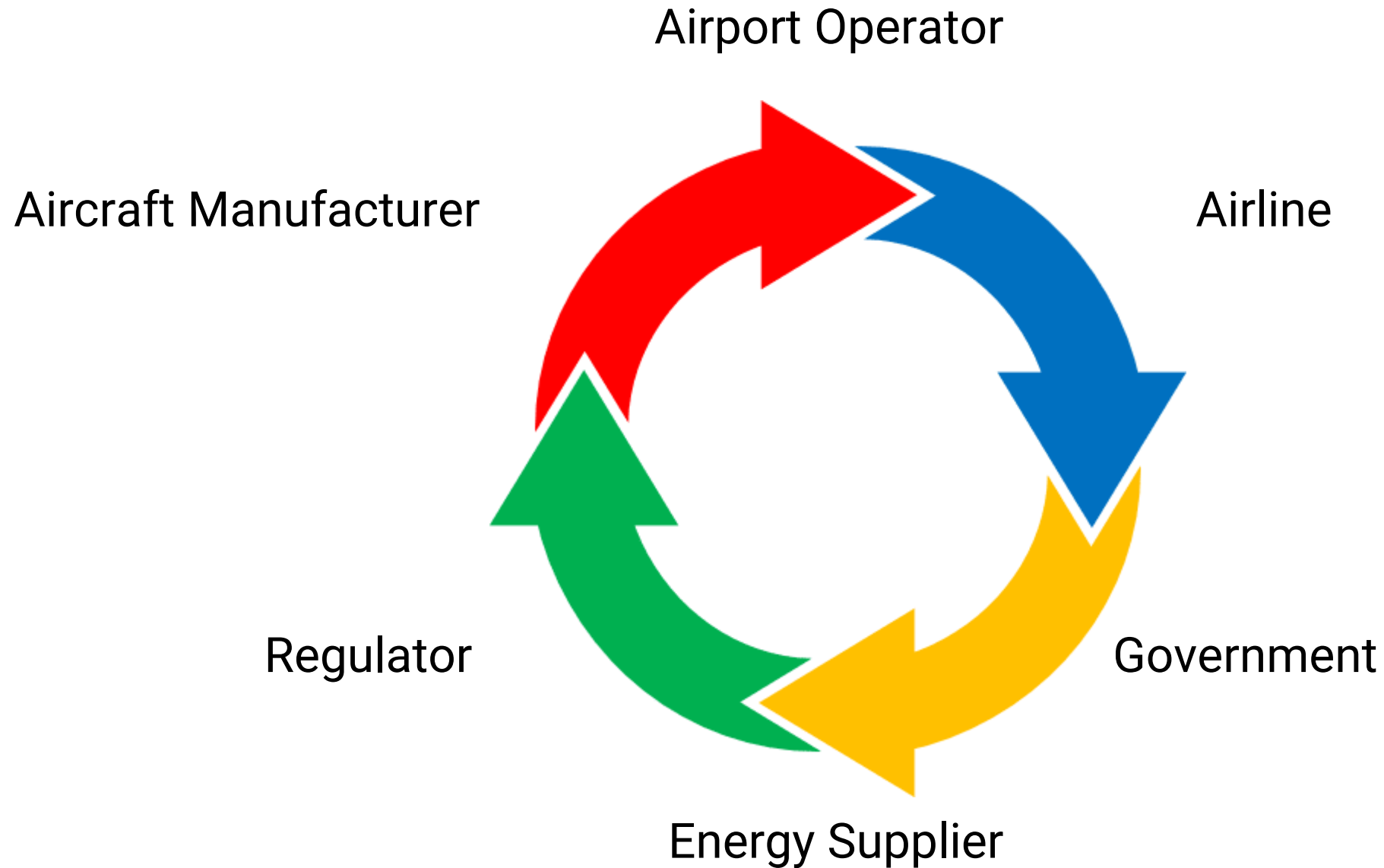

Thank you

